

VFD Product Category

DC Input



PCB Type
(Non-PFC)

[VFD-150P-48](#)
[VFD-250P-48](#)
[VFD-350P-48](#)

AC Full Range Input



PCB Type
(With PFC)

[VFD-250P-230](#)
[VFD-350P-230](#)

- ※ New products are marked in **RED**.
- ※ Please click on series names for related introduction webpages or specifications.



Enclosed Type
(With PFC)

[VFD-200C-230](#)
[VFD-350C-230](#)
[VFD-750C-230](#)

VFD Product Roadmap

※ New products are marked in RED

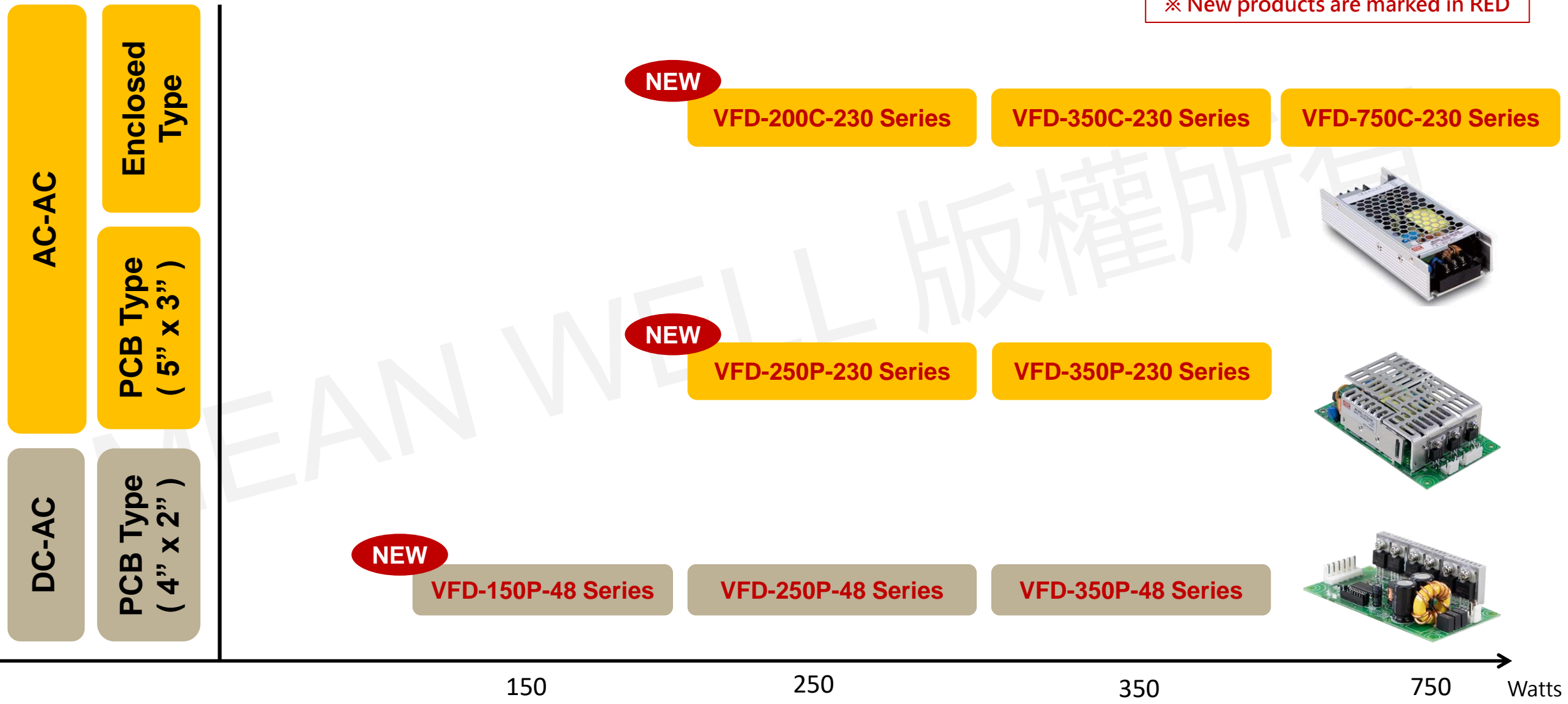

Automation Product Category

Linear Module

Widely used, stable and reliable,
very cost-effective,
Make automation integration easier!

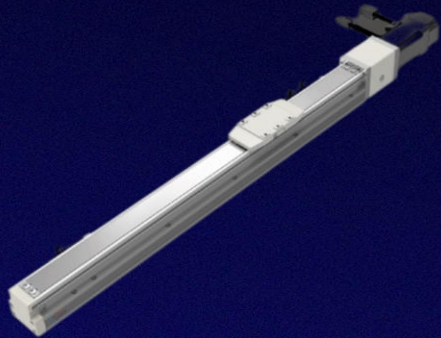

Rail Embedded Screw/Belt, Gear
and Rack, Dust-free, etc.

SCARA Industrial Robot

Focus on the pain points of robot
applications and provide the most
valuable solutions to advanced
equipment manufacturers
Robotic solution!

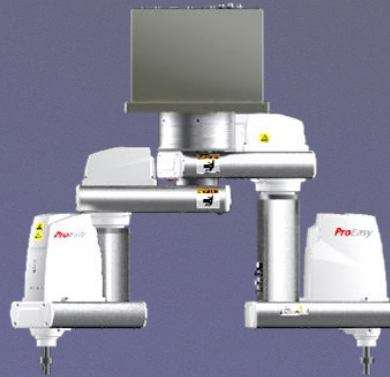

P Series/R Series/W Series/E Series

Special Equipment for PCBA Process

Focusing on the PCBA manufacturing
process, the selection of core standard
equipment such as special-shaped
plug-in machines and AOI will help
customers reduce staff and increase
efficiency.

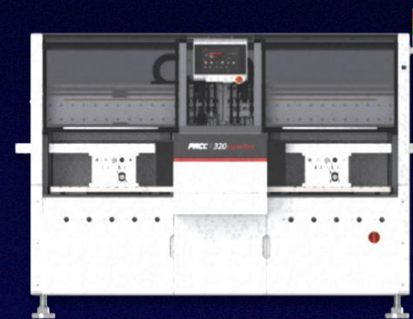

Plug-in Machine/AOI

Flexible Workstation

Focus on industry technology,
equipped with rich functional
components, fast deployment,
flexible and compatible

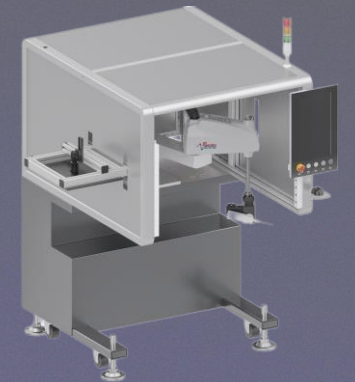

Robot Dispensing Machine/
Robot Screwing Machine

Automation Product Roadmap

Industrial Robot : P Series

Click on the series name to link to the Product Selection Guide

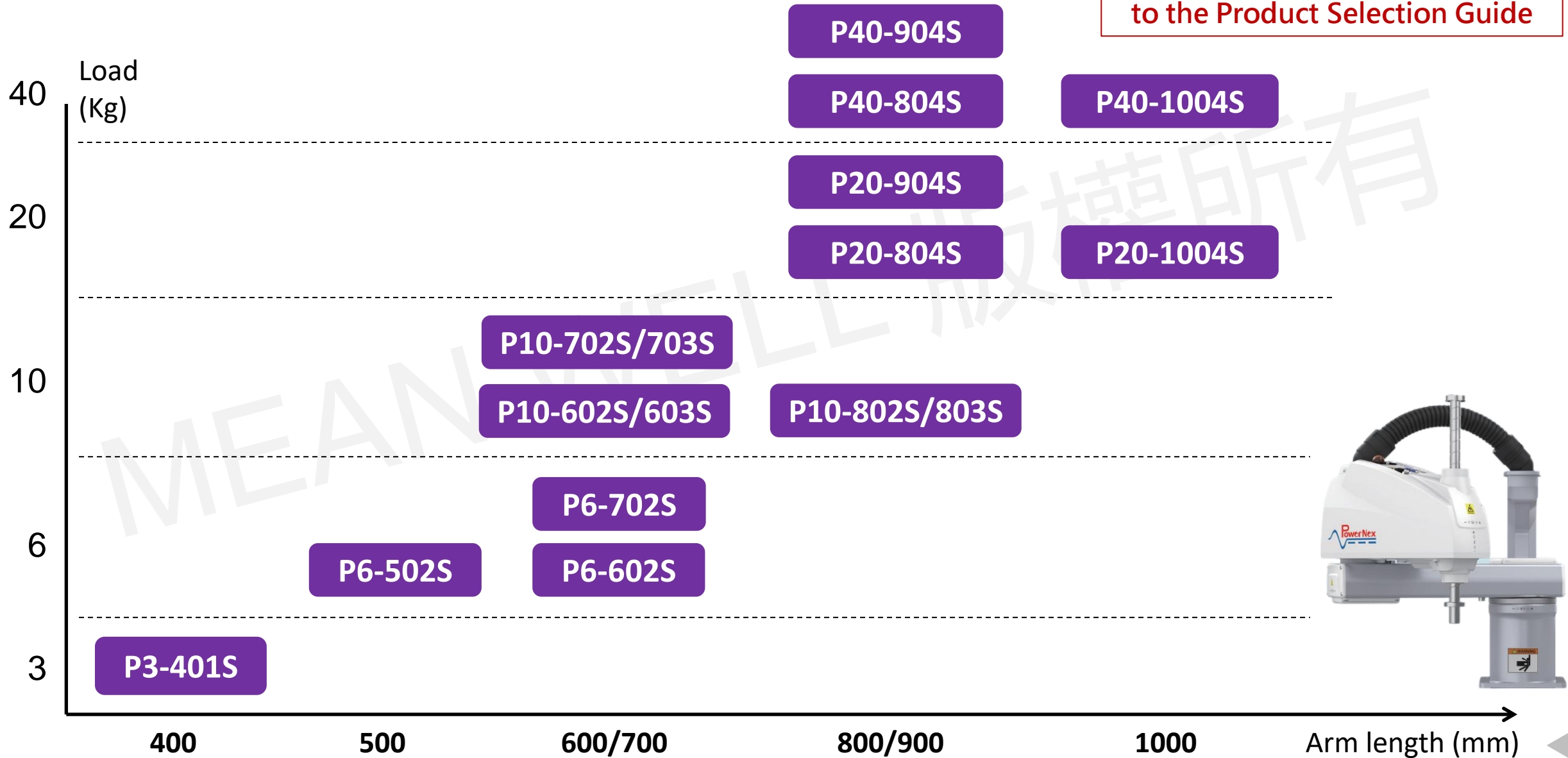

Automation Product Roadmap

Industrial Robot : R Series

Click on the series name to link to the Product Selection Guide

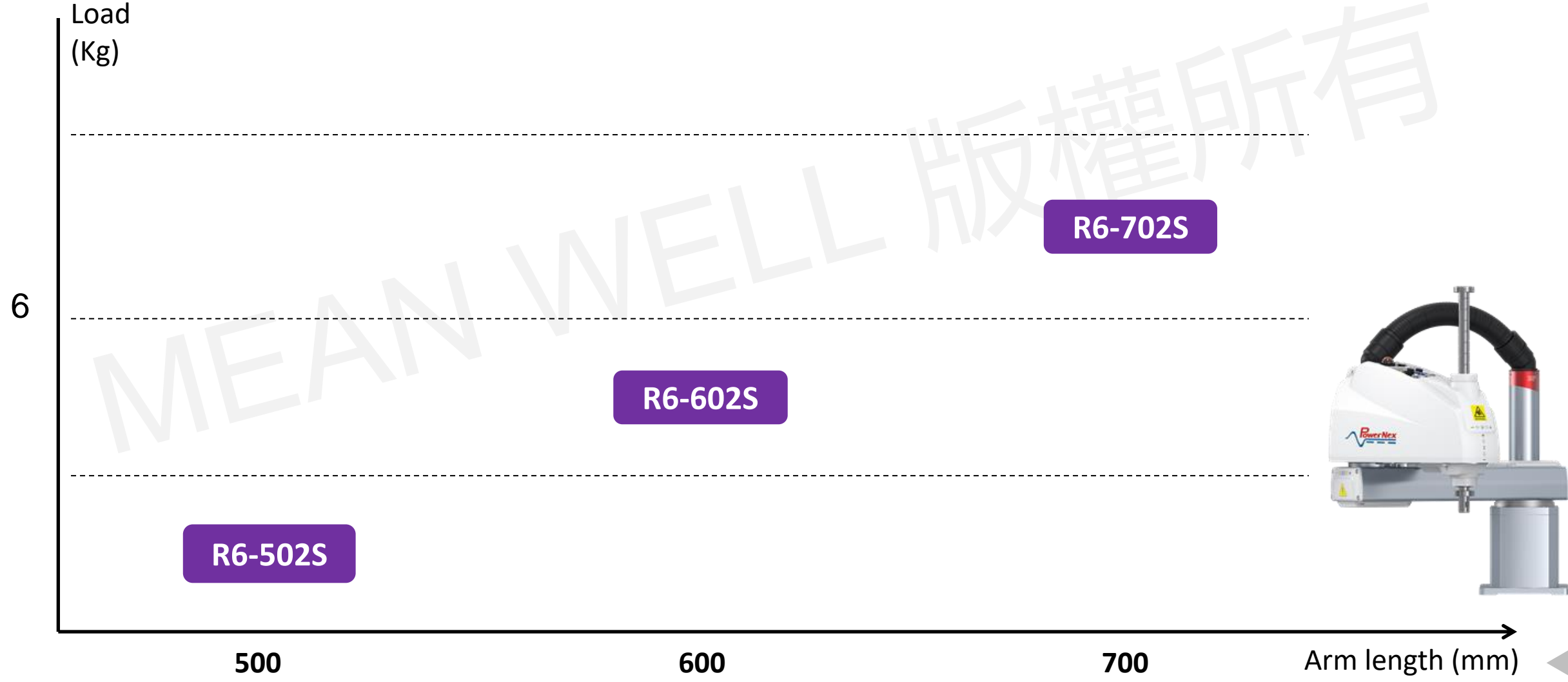

Automation Product Roadmap

Industrial Robot : W Series

Click on the series name to link to the Product Selection Guide

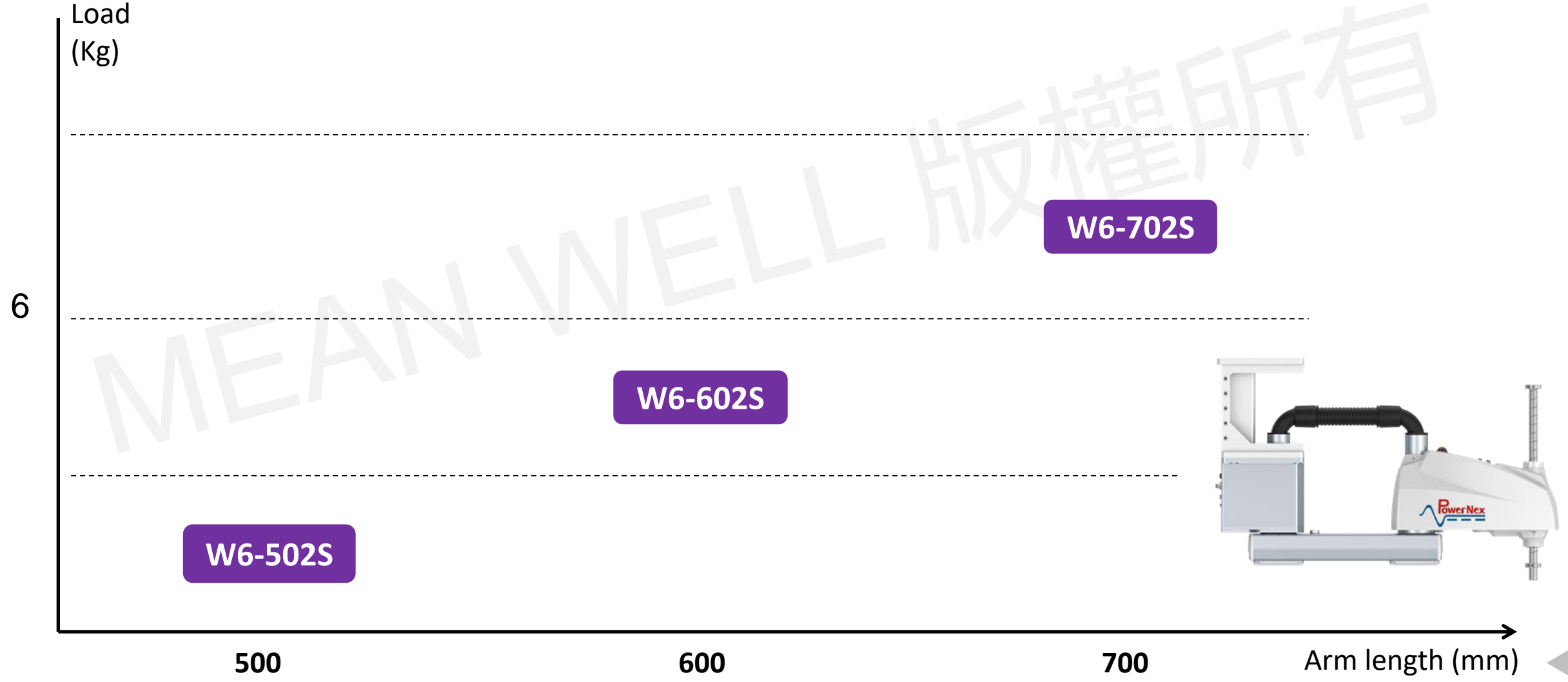

Automation Product Roadmap

Industrial Robot : E Series

Click on the series name to link to the Product Selection Guide

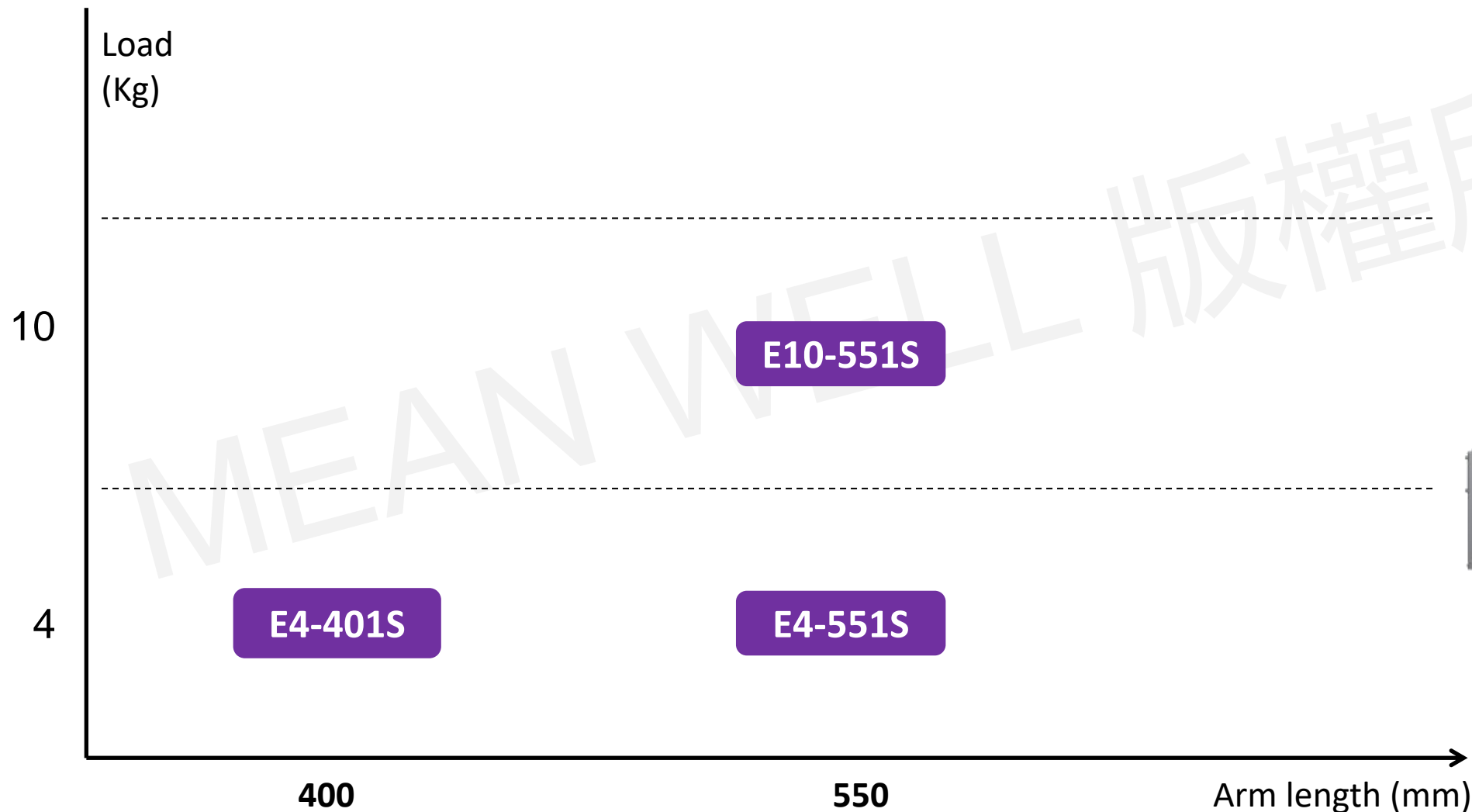

Automation Product Roadmap

Industrial Robot : D Series

Click on the series name to link to the Product Selection Guide

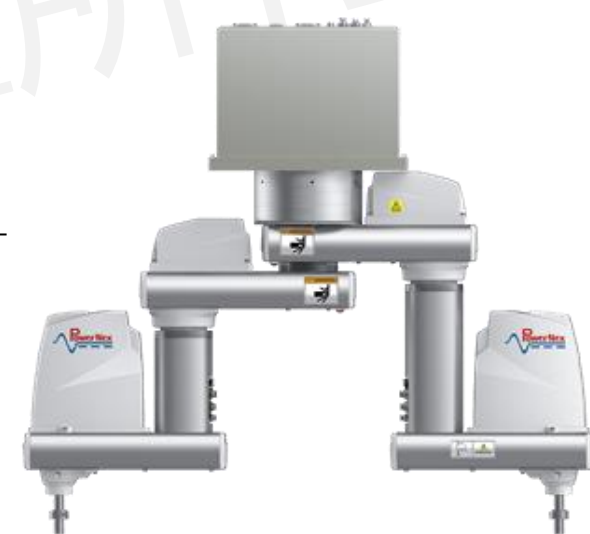
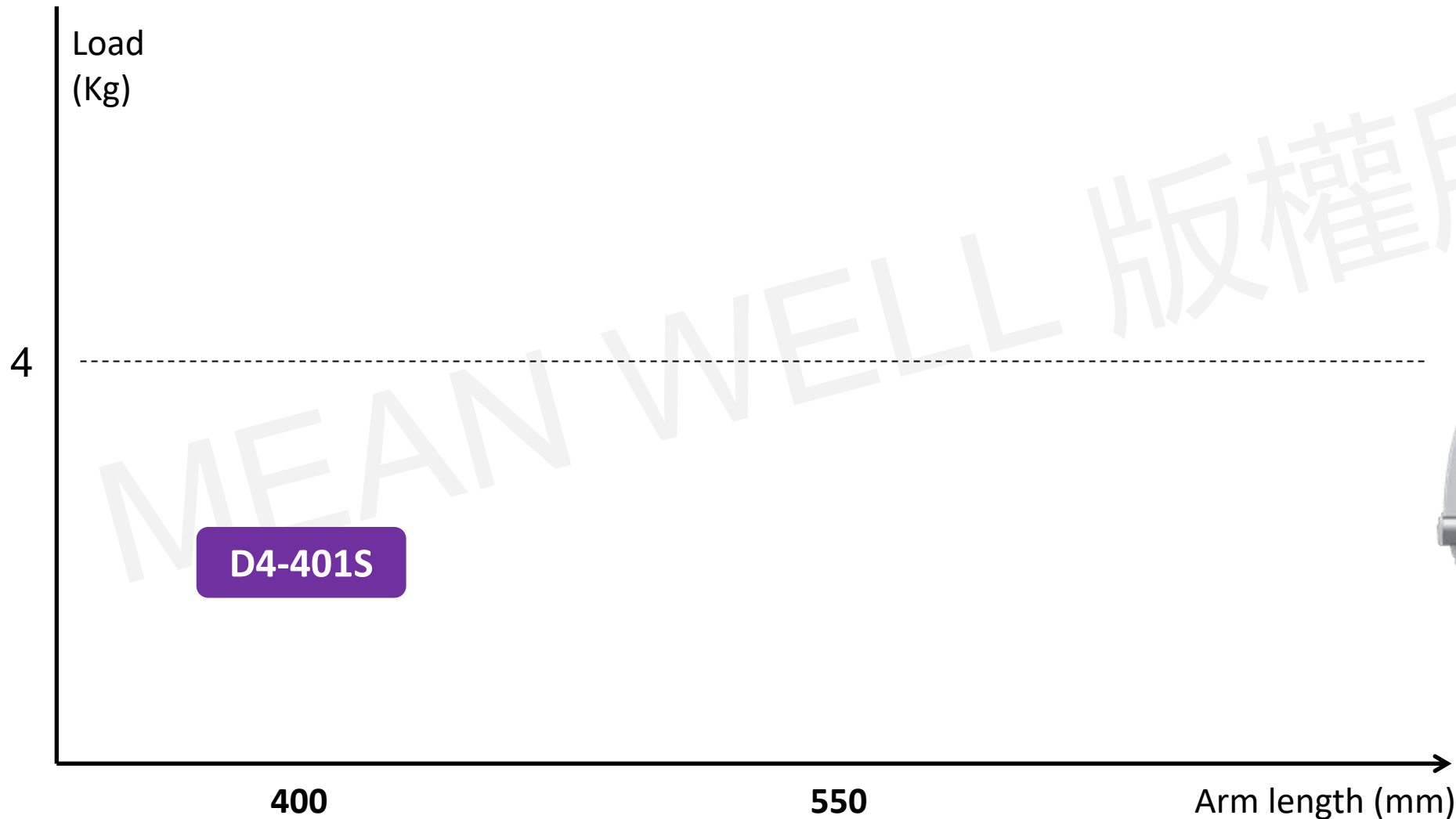

Automation Product Roadmap

Industrial Robot : CE Series

Click on the series name to link to the Product Selection Guide

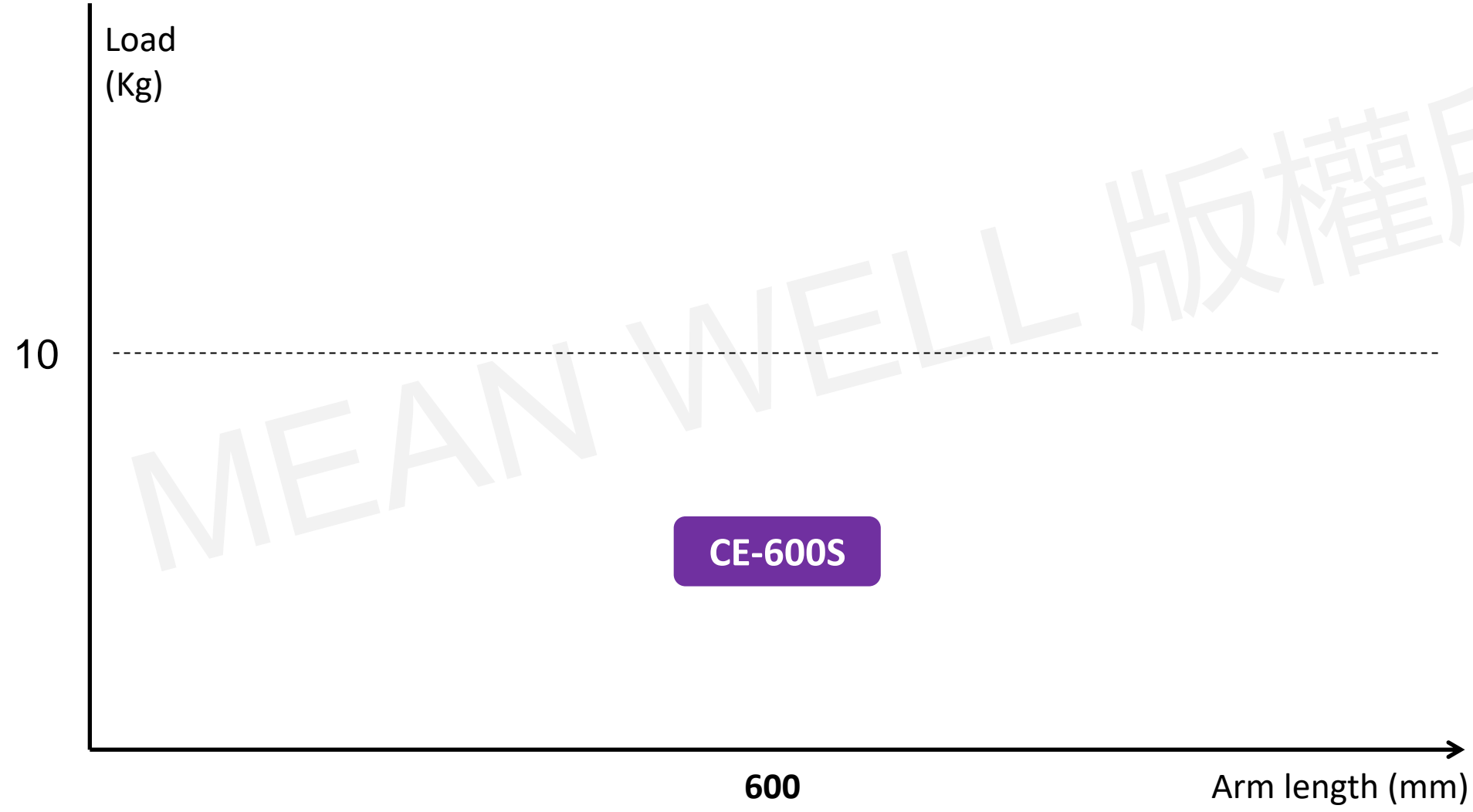

Automation Product Roadmap

Industrial Robot : CP Series

Click on the series name to link to the Product Selection Guide

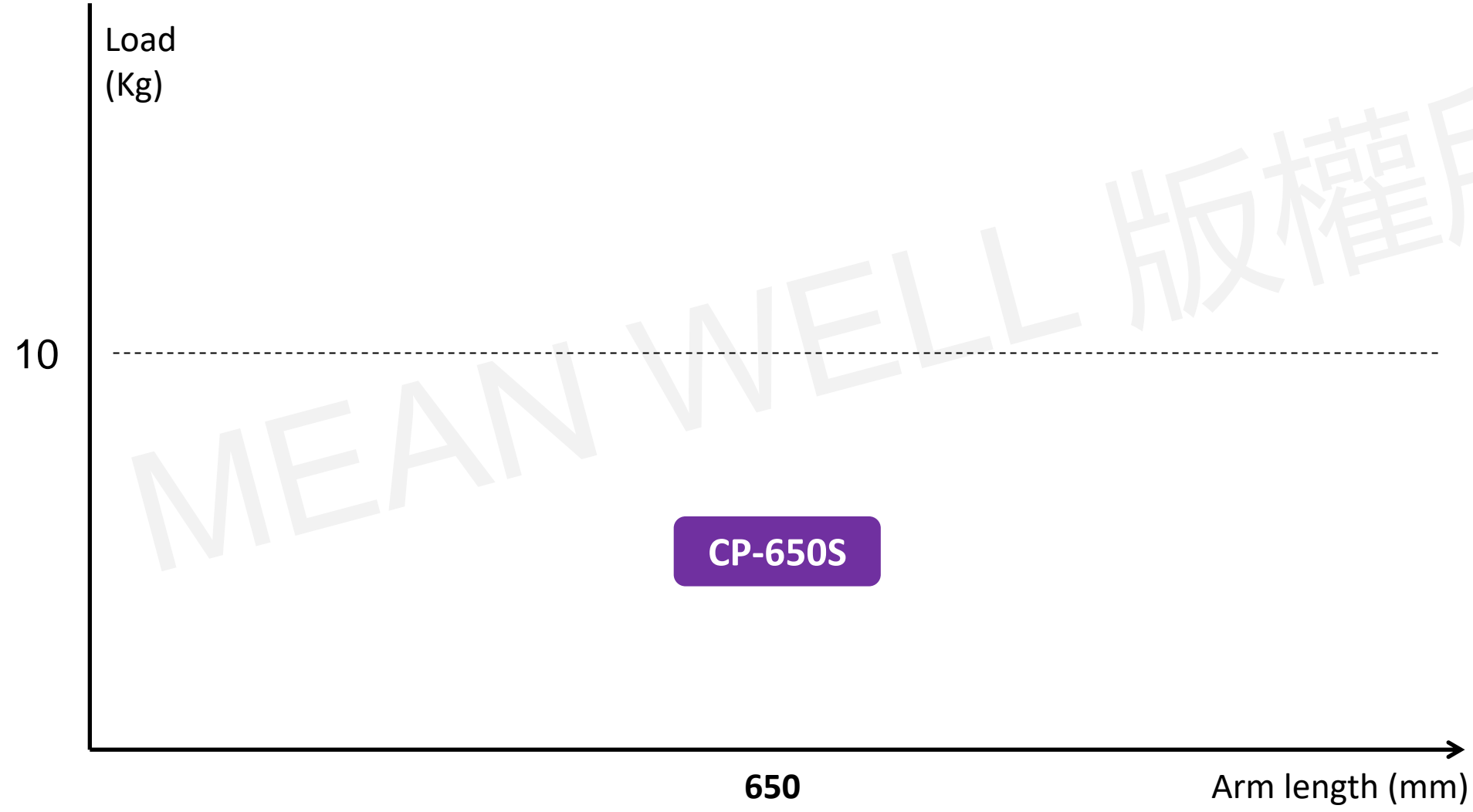

Automation Product Roadmap

Irregular Shape Plug-in Machine: Superfast Series

Click on the series name to link to the Product Selection Guide

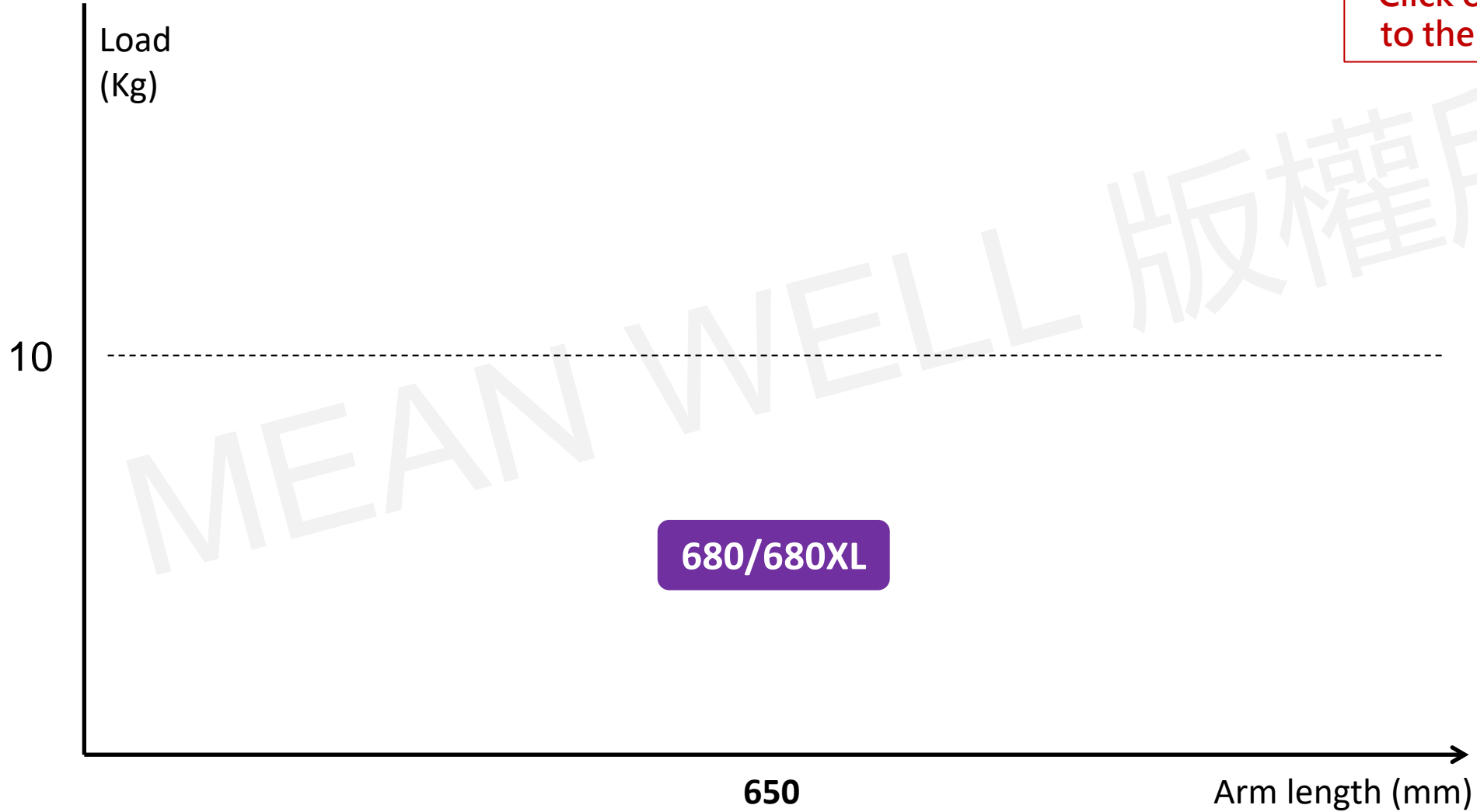

Automation Product Roadmap

Single-Station Automation > Sealant/Adhesive Solutions

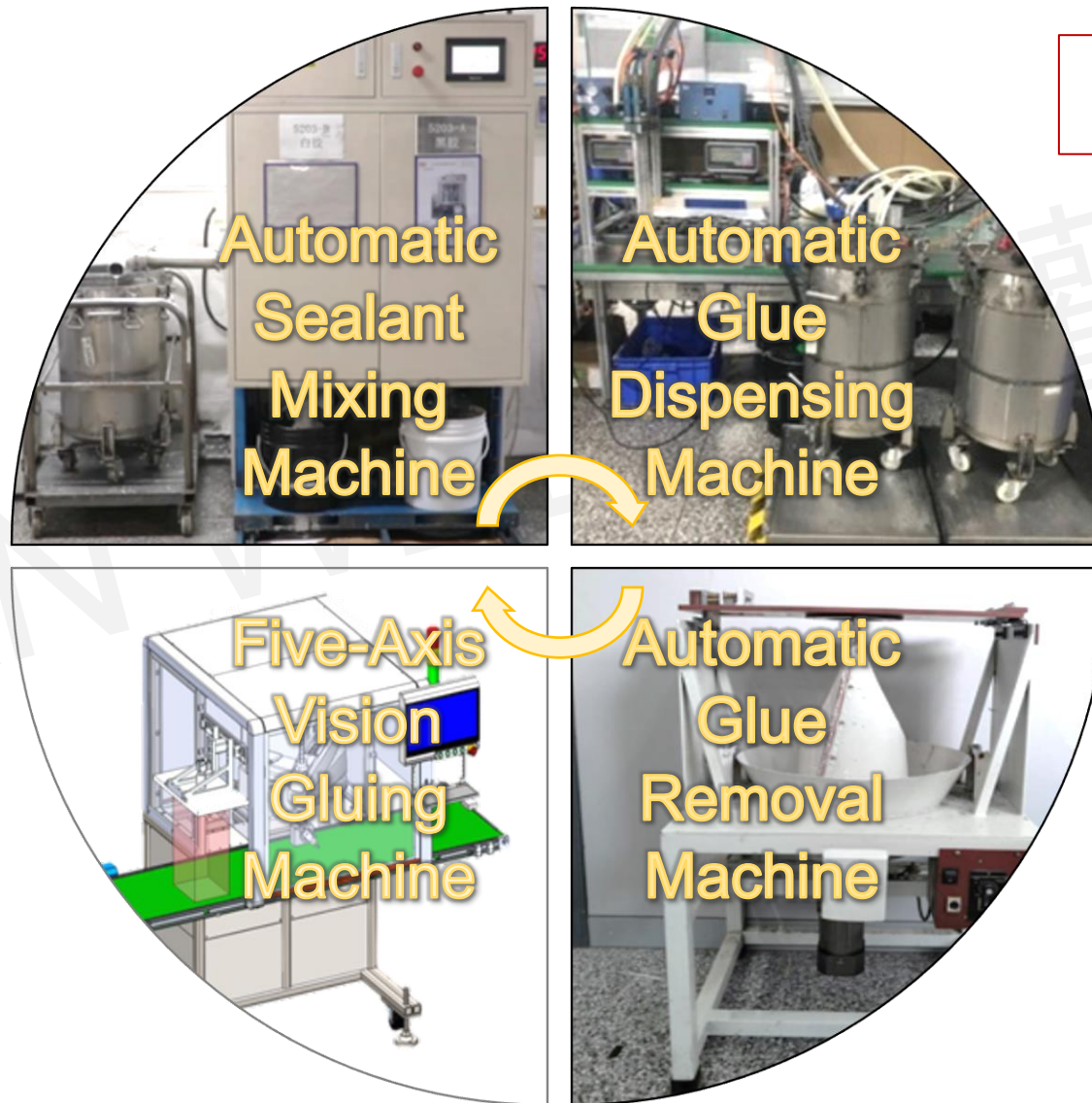

Click on the series name to link to the Product Selection Guide

MEAN WELL 所有

Automation Product Roadmap

Single-Station Automation > Electrical Test Solutions

